

MC Series Floor Machines

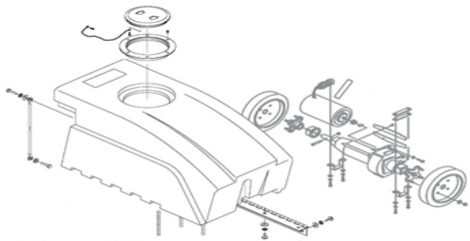

FLOOR-EQUIPMENT-PARTS.COM

Model:

- MC-16 830519, 115V
- MC-16 830686, 240V
- MC-19 830512, 115V
- MC-19 830688, 240V
- MC-22 830528, 115V
- MC-22 830534, 115V
- MC-22 831195, 240V

OPERATION

SERVICE

PARTS

CARE

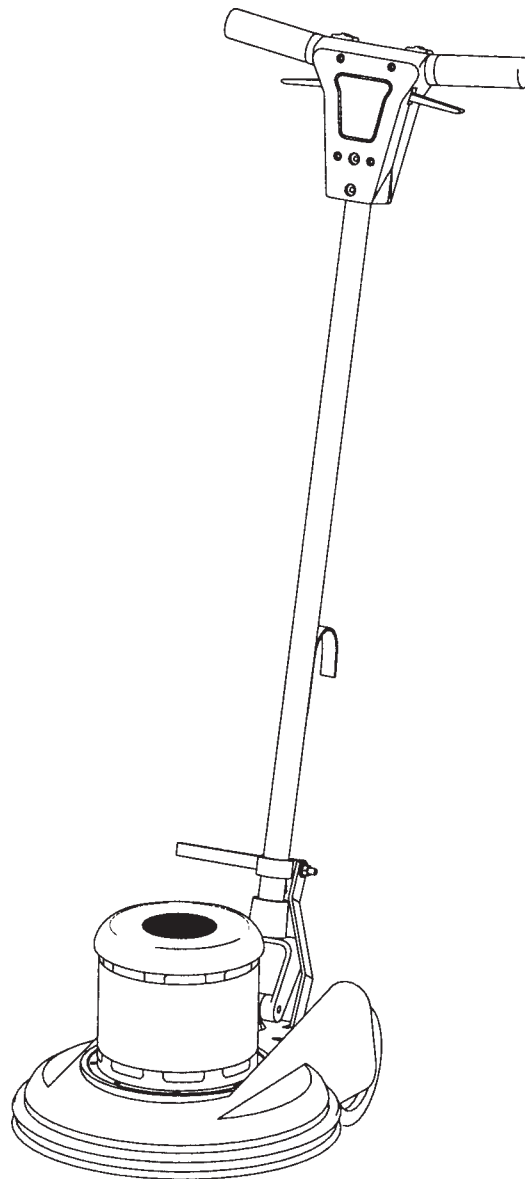

Revised 2/97

Minuteman[®]

FOR COMMERCIAL USE ONLY

IMPORTANT SAFETY INSTRUCTIONS

When using an electrical appliance, basic precautions should always be followed, including the following:

READ ALL INSTRUCTIONS BEFORE USING

WARNING - To reduce the risk of fire, electric shock, or injury:

- Do not leave appliance when plugged in. Unplug from outlet when not in use and before servicing.

WARNING

To reduce the risk of electrical shock - Do not expose to rain. Store indoors.

- Do not allow to be used as a toy. Close attention is necessary when used by or near children.
- Use only as described in this manual. Use only manufacturer's recommended attachments.
- Do not use with damaged cord or plug. If appliance is not working as it should, has been dropped, damaged, left outdoors, or dropped into water, return it to a service center.
- Do not pull or carry by cord, use cord as a handle, close a door on cord, or pull cord around sharp edges or corners. Do not run appliance over cord. Keep cord away from heated surfaces.
- Do not unplug by pulling on cord. To unplug, grasp the plug, not the cord.
- Do not handle plug or appliance with wet hands.
- Do not put any object into openings. Do not use with any opening blocked; keep free of dust, lint, hair, and anything that may reduce air flow.
- Keep hair, loose clothing, fingers, and all parts of body away from openings and moving parts.
- Do not pick up anything that is burning or smoking, such as cigarettes, matches, or hot ashes.
- Do not use without dustbag and/or filters in place.
- Turn off all controls before unplugging.
- Use extra care when cleaning on stairs.
- Do not use to pick up flammable or combustible liquids such as gasoline or use in areas where they may be present.
- Connect to a properly grounded outlet only. See grounding instructions.

SAVE THESE INSTRUCTIONS

INSPECTION

Carefully unpack and inspect your machine for shipping damage. Each unit is tested and thoroughly inspected before shipment, and any damage is the responsibility of the delivery carrier who should be notified immediately.

WARNING

- Read Instruction Manual before operating this piece of equipment.
- To reduce the risk of fire use only commercially available floor cleaners and waxes intended for machine application.
- Risk of explosion - floor sanding can result in an explosive mixture of fine dust and air. Use floor sanding machine in a well-ventilated area free from any flame or match.
- Electrical motors and components can cause an explosion when operated near volatile materials and vapors. Do not use this machine near flammable materials such as solvents, thinners, fuels, grain dust, etc.

ELECTRICAL - 115 Volt

Model MC830519, MC830512, MC830528, MC830534

This machine is designed to operate on a standard 15 amp. 120 volt, 60 hz, AC circuit. Voltages below 105 volt AC or above 125 volts AC could cause serious damage to the motor.

ELECTRICAL - 240 Volt

Model MC830686, MC830688, MC831195

This machine is designed to operate on a standard 16 amp. type L fused 230 volt, 50 hz, AC circuit. Voltages below 200 volt AC or above 250 volts AC could cause serious damage to the motor.

GROUNDING INSTRUCTIONS

- This floor finishing machine should be grounded while in use to protect the operator from electric shock. The machine is equipped with a three-conductor cord and a three-prong grounding type attachment plug to fit the proper grounding type receptacle. The green (or green and yellow) conductor in the cord is the grounding wire. Never connect this wire to other than the grounding pin of the attachment plug.
- Floor Finishing Machines Rated Less Than 150 Volts - If the machine is provided with an attachment plug as shown in Sketch A it is intended for use on a 120-volt (nominal) circuit. If a properly grounded receptacle as shown in Sketch A is not available, an adapter as shown in Sketch C is available and should be installed as shown in Sketch B if the outlet box that houses the receptacle is grounded. Be sure to fasten the grounding tab with the faceplate screw.
- Floor Finishing Machines Rated More than 150 Volts - If the machine is provided with an attachment plug as shown in Sketch D, it is intended for use on a nominal 240 volt circuit. No adapter is available for this plug.

ADAPTER (Not allowable in Canada)

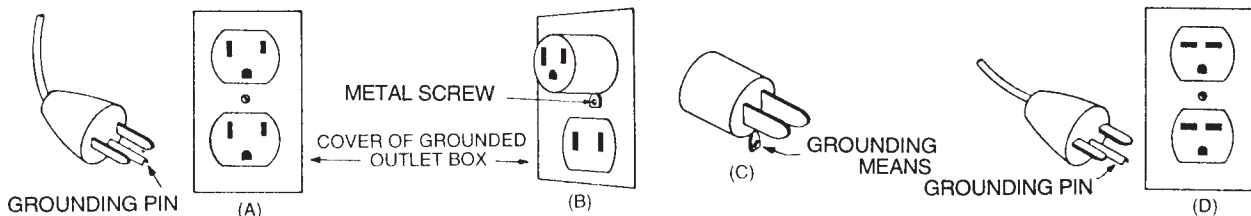

POUR USAGE COMMERCIAL SEULEMENT

MODE D'EMPLOI SECURITAIRE

Lorsque l'on utilise un appareil électrique, des précautions de base doivent toujours être suivies telles que:

BIEN LIRE LE MODES D'EMPLOI AVANT USAGE

AVERTISSEMENT - Pour réduire les risques de feu, choc électrique ou blessure:

- Ne pas quitter l'appareil lorsque la prise de courant est branchée. Débrancher de la sortie électrique lorsque la machine n'est pas en usage ou pour en faire le service.

AVERTISSEMENT - Pour réduire le risque de choc électrique - Ne pas exposer à la pluie - Entreposer à l'intérieur.

- Ne pas permettre l'usage comme jouet. Etre très prudent lorsque l'appareil est utilisé en présence d'enfants.
- Utiliser tel que prescrit dans le livre d'opération et seulement avec les attachements recommandés par le fabricant.
- Ne pas s'en servir avec corde ou prise de courant endommagée. Si l'appareil ne fonctionne pas ou a été échappé, endommagé, entreposé à l'extérieur ou déposé dans l'eau, l'appareil devrait être envoyé à un département de service pour inspection.
- Ne pas tirer ou porter par le câble ou se servir du câble comme poignée. Ne pas fermer de portes sur le câble ou tirer le câble près d'objets pointus. Ne pas conduire l'appareil en écrasant le câble et soyez certain de protéger le câble entre toutes surfaces de chauffage.
- Ne pas débrancher en se servant du câble. Pour débrancher tirer sur la prise et non sur le câble.
- Ne pas manipuler la prise ou l'appareil avec les mains mouillées.
- Ne placer aucun objet dans la sortie et ne pas s'en servir si la sortie est obstruée. Eliminer toute poussière, maillon, cheveux ou quoique ce soit qui pourrait réduire le mouvement d'air.
- N'exposer aucun cheveux, vêtement, doigts ou autres aux ouvertures de l'appareil.
- Ne rien ramasser de ce qui brûle ou de fumée tels que cigarettes, allumettes ou cendres en feu.
- Ne pas employer sans filtre de poussière ou autre en position.
- Fermer tous les contrôles après utilisation.
- Soyez très prudent lors du nettoyage d'escaliers.
- Ne pas ramasser de liquide inflammable ou combustible tel que gazoline et ne pas utiliser dans les endroits où ces derniers pourraient être présent.
- Brancher dans une prise avec une prise de terre seulement. Voir références pour prise de terre.

**CONSERVEZ CES RECOMMANDATIONS
DE MODE D'EMPLOI**

INSPECTION

Déballer soigneusement en constatant s'il y a lieu tout dommage apparent. Chacune des pièces d'équipement est entièrement inspectée à l'usine et tout dommage de transit est la responsabilité de la compagnie de transport qui devrait être prévenue immédiatement.

AVERTISSEMENT

- S.V.P. lire le manuel d'instruction avant d'opérer cette pièce d'équipement.
- Pour réduire le risque d'incendie, se servir de ces appareils uniquement pour usage commercial et avec les produits contruits spécifiquement pour usage avec ces appareils.
- Les moteurs électriques peuvent être la cause d'explosion si ils sont utilisés près de matériaux ou de vapeurs explosives. Ne pas opérer près de matériaux inflammables tels que solvant, essence, poussière de grain etc.

ELECTRICITE - 115 Volt

Modèles MC830519, MC830512, MC830528, MC830534

Ces appareils sont conçus pour opérer sur un circuit standard de 15 amp, 120 volt, 60 hz, circuit AC. Tout voltage en bas de 105 volt AC ou au-delà de 125 volts AC pourrait occasionner des dommages au moteur.

ELECTRICITE - 240 Volt

Modèles MC830686, MC830688, MC831195

Ces appareils sont conçus pour opérer sur un circuit standard AC de 16 amp, fusible type L 230 volt, 50 hz. Tout voltage en bas de 200 volt AC ou au-delà de 250 volts AC pourrait occasionner des dommages au moteur.

INSTRUCTIONS POUR PRISE DE TERRE

- Ces appareils doivent posséder une prise de terre pour protéger l'opérateur contre les chocs électriques. Cet appareil est muni d'une corde électrique à trois fils et d'un receptacle à trois fourchons et prise de mise à terre pour s'accorder dans un receptacle avec prise de mise à terre réciproque. Le fil conducteur vert (ou vert et jaune) de la corde électrique est le fil designé comme prise de mise à terre. Ne jamais relier ce fil à un fil autre que celui de prise de mise à terre.
- Appareils estimés à moins de 150 volts - Si ces appareils offrent une prise de courant tel que dans le croquis A, ils sont destinés pour utilisation avec un circuit de 120 volts. Si un receptacle avec prise de mise à terre n'est pas disponible tel que montré au croquis A, un adapteur tel que vu au croquis C est disponible et devrait être installé tel que montré au croquis B si la boîte électrique est munie d'une prise de mise à terre. Assurez-vous de bien relier la patte de prise avec la vis.
- Appareils destinés à plus de 150 volts - Si ces appareils offrent une prise de courant tel que démontré au croquis D, ils doivent être utilisés avec un circuit de 240 volts. Aucun adapteur n'est disponible pour cette prise.

ADAPTEUR (Non requis au Canada)

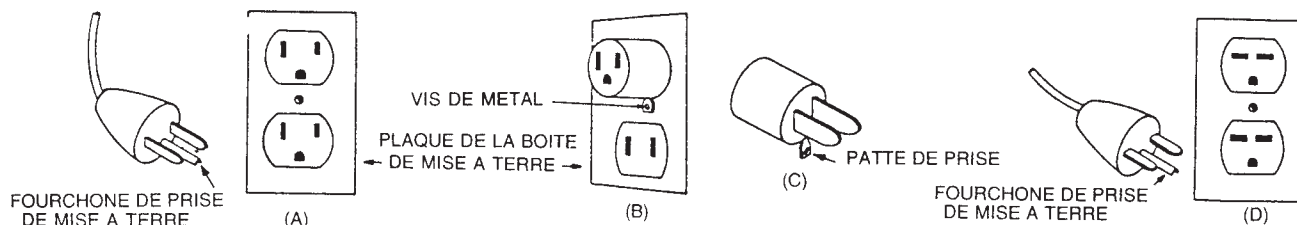

USER MAINTENANCE INSTRUCTIONS

All service and repair should be performed by a qualified electrician. No user serviceable components are employed in this equipment. No lubrication of the motor is required.

CORD STORAGE

While not in use storage can be accomplished by winding cord around handle assy. Cord should be completely unwound during operation.

- Do not use with damaged cord or plug. If appliance is not working as it should, has been dropped, damaged, left outdoors, or dropped into water, return to service center.
- Do not pull or carry by cord, use cord as handle, close a door on cord, or pull cord around sharp edges or corners. Do not run appliance over cord. Keep cord away from heated surfaces.
- Do not unplug by pulling cord. To unplug, grasp the plug, not the cord.
- Do not handle plug or appliance with wet hands.
- Always unplug the machine when removing brush. This equipment should be stored indoors and not exposed to rain.

OPERATION

The brush is attached in the following manner: Tip machine backward with handle on floor. Brush is then inserted over the lugs on the bottom of the gear unit and twisted to the left. This secures the clutch plate of the brush over the lugs on the gear unit in the correct driving position.

LOWER HANDLE ASSEMBLY TO WAIST HIGH POSITION AND LOCK.

Due to the rotation of a single disc machine, it will naturally have a tendency to move to the right or left, depending on the operator's slight pressure either up or down on the handle. If the handle is lifted slightly up, the machine will travel to the right; a downward pressure, and it will travel to the left. It is this maneuverability that enables an operator to cover large areas in a short time with the least amount of effort. The machine can be made to operate without travel by balancing . . . KEEPING THE BRUSH PRESSURE ON THE FLOOR EQUAL. With a few minutes of practice in a large area, you will have perfect fingertip control of the machine. This equipment is equipped with trigger safety interlock. Refer to diagram pictured.

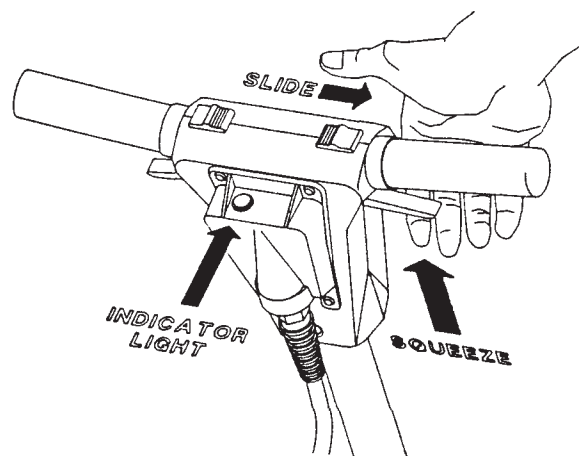

MODEL MC830519, MC830512
 MODEL MC830528, MC830534

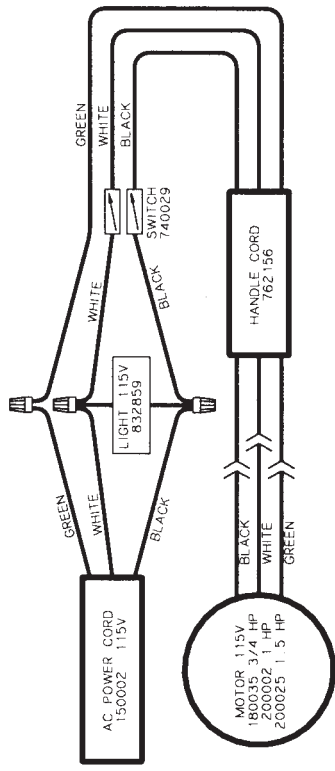

WIRING DIAGRAM SINGLE SPEED 115V

MODEL MC830686, MC830688, MC831195

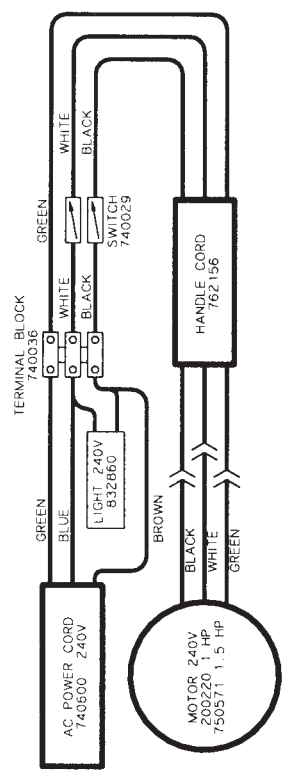

WIRING DIAGRAM SINGLE SPEED 240V

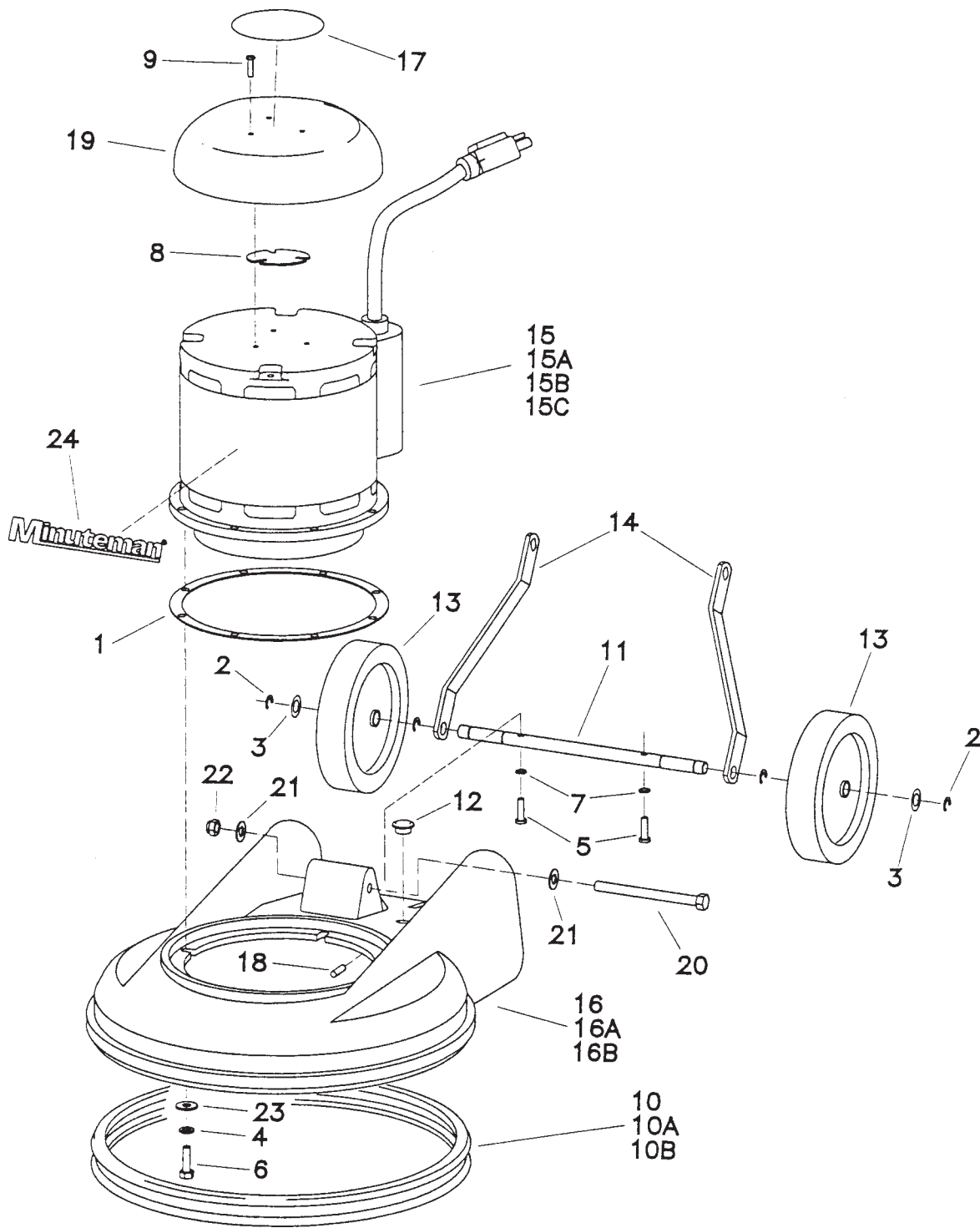

PARTS LIST

Item	Part No.	Qty	Description
1	16007	1	Gasket
2	711713	4	Retaining Ring
3	711524	2	WSR-Wave
4	711545	4	WSR-Helical 5/16
5	710381	2	SCR-MC 1/4-20 x .87
6	711229	4	BLT-HH 5/16-18 x .87
7	711544	2	WSR-Helical 1/4Nut-Nyloc 5/16
8	805635	1	Cork Gasket
9	710153	3	SCR-MC 10-32 x .37
10	803078	1	Bumper MC-16
10A	803080	1	Bumper MC-19
10B	803081	1	Bumper MC-22
11	803609	1	Axle
12	804479	1	Plug Rubber
13	804545	2	Wheel Grey
14	807248	2	Handle Brace
15	200002	1	Motor, 1 HP w/Gear 115V, 60 hz
15A	200220	1	Motor, 1 HP, 230V, 50 hz
15B	200025	1	Motor, 1 1/2 HP, 115V, 60 hz
15C	750571	1	Motor, 1 1/2 HP, 230V, 50 hz
16	803087POL	1	MC-16 Base
16A	803095POL	1	MC-19 Base
16B	803129POL	1	MC-22 Base
17	715653	1	Decal
18	829296	1	Roll Pin 1/4 x 7/8
19	160048PTD	1	Motor Cover
20	760261	1	Bolt, Handle Yoke
21	711515	2	WSR-Flat .40 x .81 x .06
22	711375	1	Nut-Nyloc 3/8-16
23	711575	4	WSR-Flat .31 x .75 .06
24	715382	1	Decal - Minuteman

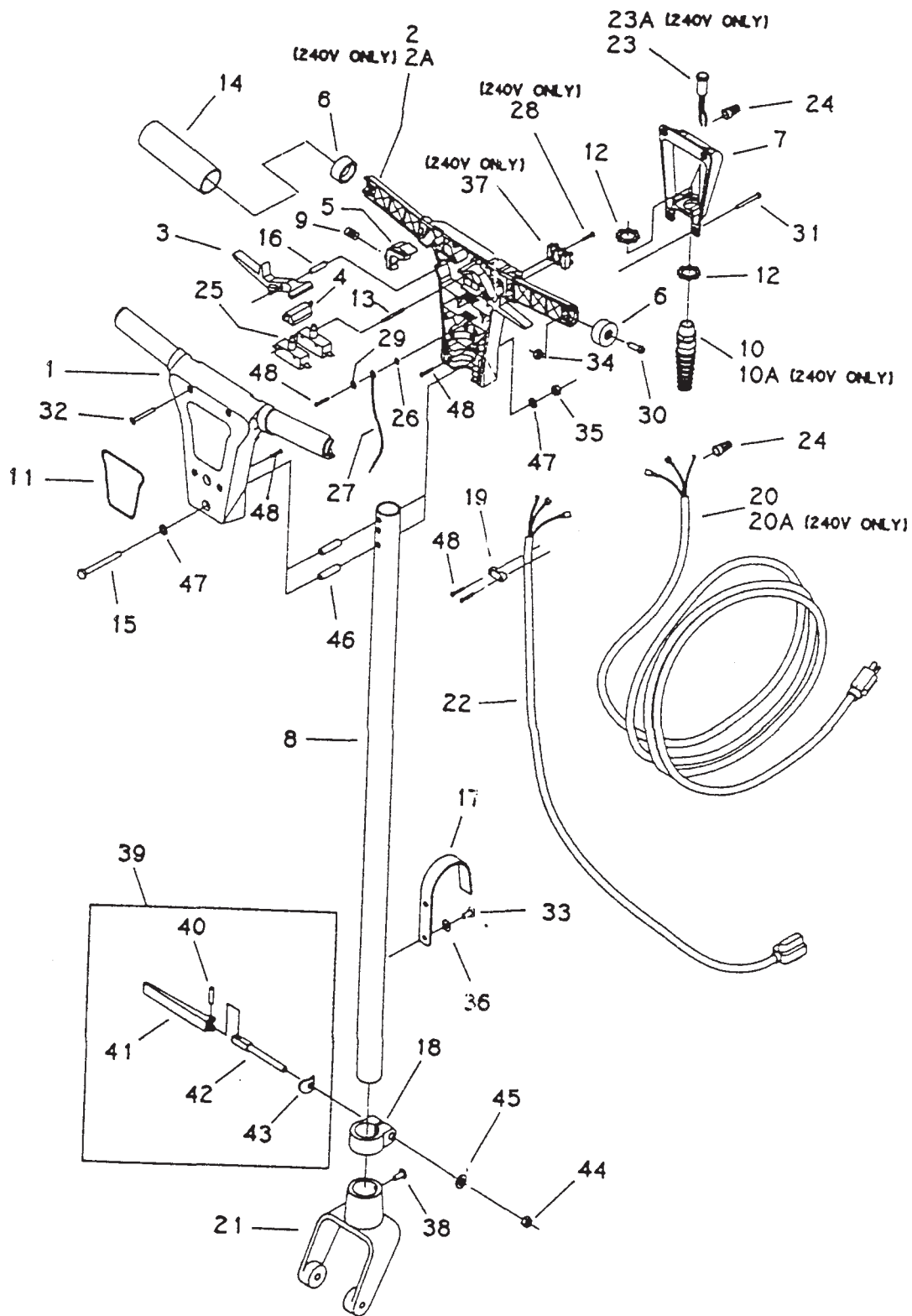

PARTS LIST

Item	Part No.	Qty.	Description
1	190003	1	Switch Box Front
2	190004	1	Switch Box Rear
2A	190004MCH	1	Switch Box Rear, 240V
3	190007	2	Switch Trigger
4	190008	1	Switch Cap
5	190009	2	Safety Button
6	190006	2	End Cap
7	190005	1	Electrical Box Rear
8	190012	1	Tube Handle
9	190015	2	Trigger Spring
10	150003	1	Strain Relief, 115V
10A	150004	1	Strain Relief, 240V
11	715175	1	Decal, Minuteman Runner
12	711400	2	Nut-Pipe Lock 1/2
13	711619	2	Roll Pin 1/8 x 1.50
14	190016	2	Foam Grip
15	710186	2	SCR-MC 1/4-20 x 2.25 TH
16	711658	2	Roll Pin 1/4 x 1.0
17	170040PLT	1	Cord Hook
18	16224	1	Handle Clamp
19	190010	1	Strain Relief
20	150002	1	Orange Cord Set, 115V
20A	740600	1	Cord Set, 240V
21	803379	1	Yoke
22	190013	1	Cord, Handle
23	832859	1	Indicator Light, 115V
23A	832860	1	Indicator Light, 240V
24	740005	3	Wire Cap 14-18
25	740029	2	Switch 1.5 HP
26	711553	1	WSR-Lock #8
27	740363	1	Wire Assy. Green w/Yellow
28	712088	2	SCR-Hi/Lo 8-18 x .75
29	711502	1	WSR-Flat 8
30	710380	2	SCR-MC 1/4-20 x .75
31	711160	4	SCR-Hi/Lo 10 x .63
32	711162	4	SCR-Hi/Lo 10 x 1.50
33	711202	2	Bolt-HH 1/4-20 x .50
34	711316	2	Nut-Hex 1/4-20
35	711373	2	Nut-Nyloc 1/4-20
36	711544	2	WSR-Helical 1/4
37	740036	1	Terminal Block, 240V
38	710579	2	SCR-MC 1/4-20 x .62
39	807674	1	Kick Lever Kit
40	806561	1	Dowel Kit
41	806558	1	Kick Lever
42	807190	1	Bolt Cam
43	806555	1	Washer Cam
44	711374	1	Nut-Nyloc 5/16-18
45	711506	1	WSR-Flat 5/16
46	190029	2	Sleeve
47	711504	4	WSR-Flat 1/4
48	711128	5	SCR Hi/Low #8-18 x .625

LIMITED WARRANTY

Minuteman International, Inc. warrants to the original purchaser/user that this product is free from defects in workmanship and materials under normal use and service for a period of three years from date of purchase. In addition, Minuteman International, Inc. will, at its option, honor labor warranty claims for the first 12 months from date of sale, provided such claims are submitted through and approved by factory authorized repair stations. Minuteman International, Inc. will, at its option, repair or replace without charge, except for transportation costs, parts that fail under normal use and service when operated and maintained in accordance with the applicable operation and instruction manuals.

This warranty does not apply to normal wear, or to items whose life is dependent on their use and care, such as belts, cords, switches, hoses, rubber parts, electrical motor components or adjustments. Parts not manufactured by Minuteman International, Inc. such as engines, batteries, battery chargers, hydraulic pumps, and tires are covered by and subject to the warranties and/or guarantees of their manufacturers. Please contact Minuteman International, Inc. for procedures in warranty claims against these manufacturers.

Special warning to purchaser — Use of replacement filters and/or prefilters not manufactured by Minuteman International, Inc. or its designated licensees, will void all warranties expressed or implied.

A potential health hazard exists without exact original equipment replacement.

All warranted items become the sole property of Minuteman International, Inc. or its original manufacturer, whichever the case may be.

Minuteman International, Inc. disclaims any implied warranty, including the warranty of merchantability and the warranty of fitness for a particular purpose. Minuteman International, Inc. assumes no responsibility for any special, incidental or consequential damages.

This limited warranty is applicable only in the U.S.A. and Canada, and is extended only to the original user/purchaser of this product. Customers outside the U.S.A. and Canada should contact their local distributor for export warranty policies. Minuteman International, Inc. is not responsible for costs or repairs performed by persons other than those specifically authorized by Minuteman International, Inc. This warranty does not apply to damage from transportation, alterations by unauthorized persons, misuse or abuse of the equipment, use of non-compatible chemicals, or damage to property, or loss of income due to malfunctions of the product.

If a difficulty develops with this machine, you should contact the dealer from whom it was purchased.

This warranty gives you specific legal rights, and you may have other rights which vary from state to state. Some states do not allow the exclusion or limitation of special, incidental or consequential damages, or limitations on how long an implied warranty lasts, so the above exclusions and limitations may not apply to you.

Minuteman[®]

World Headquarters
Minuteman International, Inc.
111 South Rohlwing Road
Addison, Illinois 60101

Minuteman Canada, Inc.
2210 Drew Road
Mississauga, Ontario
L5S 1B1

(630) 627-6900
FAX (630) 627-1130

(905) 673-3222
FAX (905) 673-5161

986410
Printed in U.S.A.